

GROVE[®] G12 Through Conduit Gate Valve

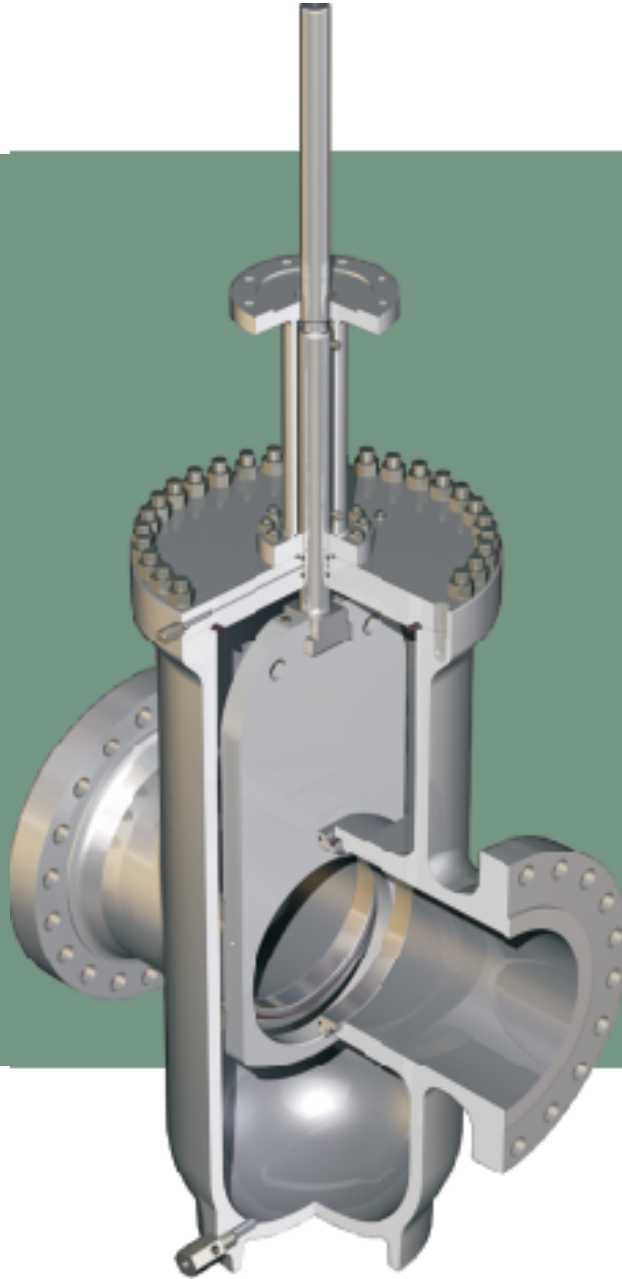

GROVE[®]

TABLE OF CONTENTS

**GROVE G12
THROUGH CONDUIT GATE VALVE**

The Company	2	
Applications	2	
General Information	2	
Design Features	3	
Optional Features	6	
Special Applications	8	
Materials Specification	10	
Valve Assembly	11	
DIMENSIONS AND WEIGHTS		
ASME Class 150	12	
ASME Class 300	13	
ASME Class 400	14	
ASME Class 600	15	
ASME Class 900	16	
ASME Class 1500	17	
ASME Class 2500	18	
QUALITY SYSTEM AND QUALIFICATION TESTING		19
TRADEMARK INFORMATION		20

G12 THROUGH CONDUIT GATE VALVE GENERAL INFORMATION

THE COMPANY

Cameron's Valves & Measurement (V&M) group is a leading provider of valves and measurement systems to the Oil and Gas industry.

The Engineered Valves division provides large-diameter valves for use in natural gas, LNG, crude oil and refined products transmission lines as well as in many other general industrial applications.

Rigorously tested, field-proven and backed by superior aftermarket service, Cameron's GROVE valves are among the best known valves in the world.

APPLICATIONS

The GROVE G12 Gate Valve is a through-conduit gate valve with a cast body.

The valve is fully in compliant with API 6D.

This series is designed for standard application, but the design is also particularly suitable for projects where special materials and trims are required.

The top entry construction allows easy maintenance in a wide range of applications such as in oil and gas pipeline main valves, manifolds, station valves, pig launcher traps and Emergency Shut Down (ESD).

The traditional field of application is in oil and gas transmission and distribution both onshore and offshore.

RANGE OF PRODUCTION

SIZE		ASME CLASS							
in.	(mm)	150	300	400	600	900	1500	2500	
2	(50)	●	●	●	●	●	●	●	
3	(80)	●	●	●	●	●	●	●	
4	(100)	●	●	●	●	●	●	●	
6	(150)	●	●	●	●	●	●	●	
8	(200)	●	●	●	●	●	●	●	
10	(250)	●	●	●	●	●	●	●	
12	(300)	●	●	●	●	●	●	●	
14	(350)	●	●	●	●	●	●	●	
16	(400)	●	●	●	●	●	●	●	
18	(450)	●	●	●	●	●	●	●	
20	(500)	●	●	●	●	●	●	●	
22	(550)	●	●	●	●	●	●	●	
24	(600)	●	●	●	●	●	●	●	
26	(650)	●	●	●	●	●	●	●	
28	(700)	●	●	●	●	●	●	●	
30	(750)	●	●	●	●	●	●	●	
32	(800)	●	●	●	●	●	●	●	
34	(850)	●	●	●	●	●	●	●	
36	(900)	●	●	●	●	●	●	●	
38	(950)	●	●	●	●	●	●	●	
40	(1000)	●	●	●	●	●	●	●	
42	(1050)	●	●	●	●	●	●	●	
48	(1200)	●	●	●	●	●	●	●	
54	(1350)	●	●	●	●	●	●	●	
56	(1400)	●	●	●	●	●	●	●	
60	(1500)	●	●	●	●	●	●	●	

G12 DESIGN FEATURES

STANDARD DESIGN FEATURES

- Bi-Directional
- Stem Seals: Self Energized Non Rolling Lip Seals
- No Side Load and Friction Drag on the Stem - Low Operating Thrust
- Stem Protector and Gate Position Indicator
- Through Conduit, Self Cleaning, Floating Slab Gate
- Self Relieving Floating Seat always in Contact with the Gate
- Metal-to-Metal Primary Seal, Protected O-Ring Secondary Seal
- Block-and-Bleed and Double-Block-and-Bleed Design
- Upper Stem Seal Gasket Replaceable with Pressure In-Line
- "Top Entry" Body for In-Line Maintenance

OPTIONAL FEATURES UPON REQUEST

- Built in Sealant Injection System for Emergency Sealing
- Reverse Acting Gate
- Graphite Packing Fire Safe Sealing
- OS&Y Bonnet Design
- Back Seat
- Metal-to-Metal with Tungsten Carbide Coating (TCC) on Seats and Gate
- Seats Skirts for Dirty Fluid Application
- Seats with Plastic Insert
- Seats with Double Piston Effect Design to have TRIPLE BARRIER from Upstream Side to Downstream Side of the Valve

SEAT CONSTRUCTION

The standard seat construction for the G12 is a self-relieving seat design

The initial seal, at extremely low pressure differentials, is obtained by the floating seats being forced against the gate by the spring.

When the gate is closed, the upstream pressure pushes the gate tightly against the down stream seat.

This results in upstream and downstream bubble-tight seals which works independently under most pressure conditions.

When the gate is open, the unbalanced pressure principle assures that both upstream and downstream seats are forced against the gate thus assuring through conduit port without access between the line and the body cavity.

Sealing is performed by both a primary Metal-to-Metal seal and a secondary, protected O-ring seal.

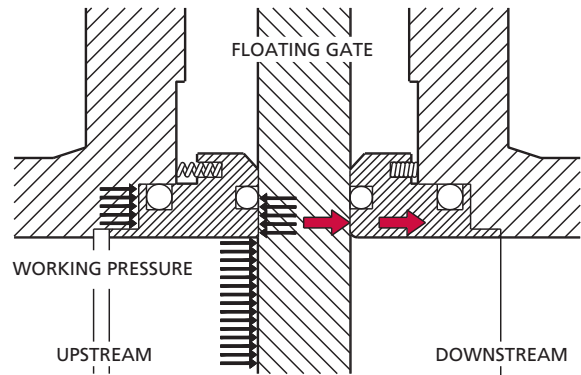

VALVE CONSTRUCTION

The cylindrical shape of the body and the cast construction allows for an optimization of material distribution which is particularly suitable for high pressure classes.

The standard construction is in full compliance with API 6D Standards.

Other codes available on request are:

ASME B16.34

ASME VIII Div. 1 or Div. 2.



G12 DESIGN FEATURES

STEM AND GATE CONSTRUCTION

The stem/gate connection guarantees the floating movement of the gate.

The slab gate is aligned between the two floating seats and between the side guides, which allows for self alignment to compensate for pipe movement and stresses in the pipeline.

Mechanical stops are adjusted to provide the vertical alignment of the gate port with the seats.

A visible gate-position indicator rod and a stem protector are provided as standard feature on handwheel, gearbox and motor operated valves.

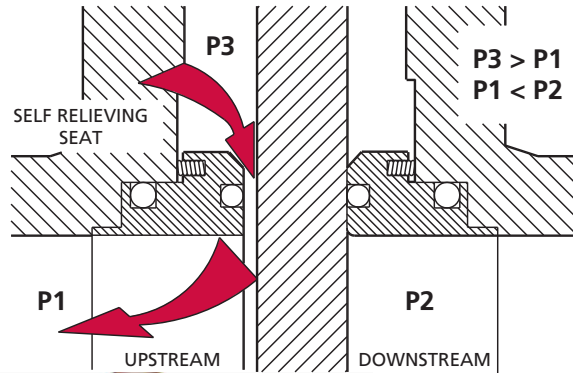
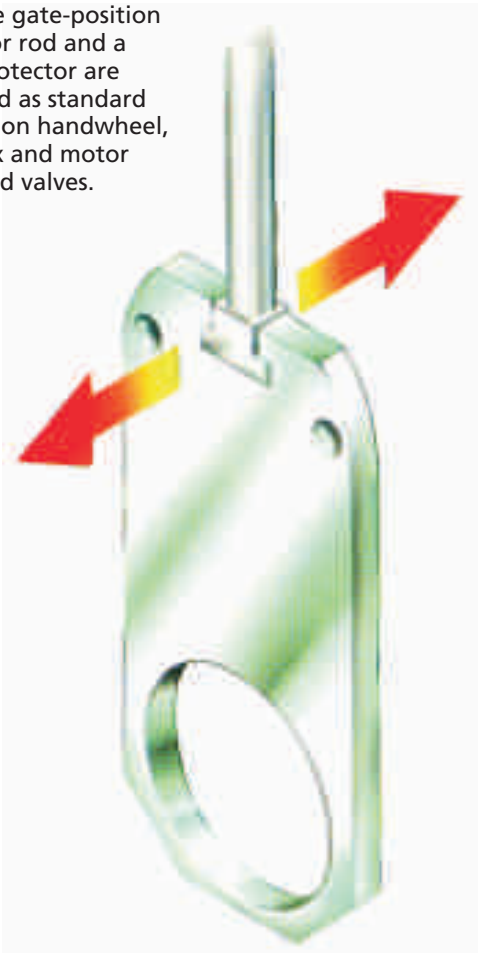

SELF RELIEVING FEATURE

The seat design features an automatic internal body relief for protection against over-pressure in the body cavity.

Over-pressurization of the valve cavity overcomes the piston effect force of the seat and moves it away from the upstream seat.

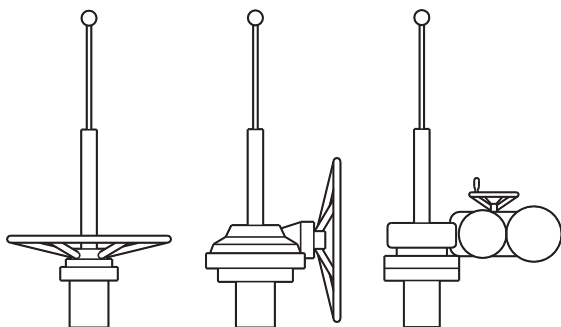

G12 STANDARD DESIGN

BODY DRAIN

In the lowest part of the body cavity, a NPT drain valve with safety plug is located.

A 1/2 in. (15 mm) NPT bonnet plug allows for flushing through bonnet and drain.

BLOCK-AND-BLEED DOUBLE-BLOCK-AND-BLEED

GROVE G12 Gate Valves are ideally suited for services requiring "Block-and-Bleed" or "Double-Block-and-Bleed".

The bubble-tight independent upstream and independent downstream seal design permits venting and draining of the line fluids from the body cavity.

INTERNAL COATING

Internal trim parts (gate, seats, stem) are usually Electroless Nickel Plated (E.N.P.).

The chemical process provides corrosion resistance and low wear to the parts during operation.

Depending on the type of the fluid, a variety of Corrosion Resistant Alloy (CRA) overlays can be applied in the critical sealing areas.

STEM SEALS

The stem is sealed with primary and secondary ring energized lip seals made from abrasion resistant material in a non rolling configuration with provision for emergency grease injection between them.

When the valve is in the closed position and the body pressure is vented to atmosphere, the secondary lip seal can be replaced.

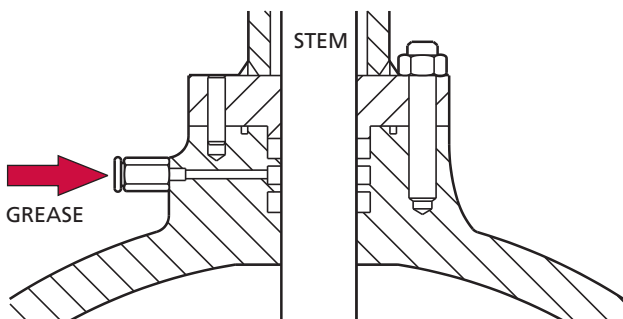

MAINTENANCE

The valve is designed to be maintained without removing the body from the line.

When the valve is in the closed position and the body pressure is vented to atmosphere, in case of damage, the secondary lip seal can be replaced by removing the yoke only.

The complete disassembly of yoke and bonnet can be achieved after line depressurization without removing the gate from the seats. In this case, the stem gasket and the body bonnet O-ring can be replaced.

Using a simple wedge tool the gate can be disengaged from the seats and parts can be disassembled, checked and eventually replaced if necessary.

The valves are equipped with handling devices such as lifting lugs and eye-bolts.

G12 OPTIONAL FEATURES

TRANSITION PIECES

Transition pieces can be welded to the valve during the manufacturing process.

A wide variety of weld procedures that meet most international requirements are available.



G12 Gate Valve 40 inch ASME Class 1500

EMERGENCY SEAT SEAL

If a high content of debris contaminates the fluid, the possibility of leakage, due to erosion, is greater than when the valve is used for normal service.

All GROVE G12 Gate Valves are designed not to require sealants; however, if the Metal-to-Metal primary seal and the secondary O-ring seal are damaged, an emergency Shut-Off may be obtained with a sealant injected into an optional, specially designed, groove in the seat ring assembly.

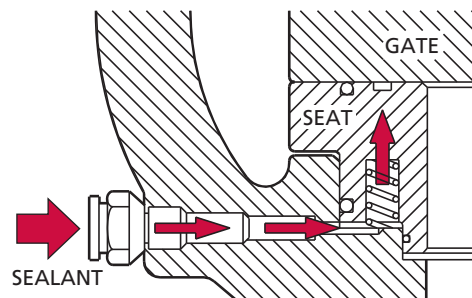

STEM EXTENSIONS

GROVE G12 Gate Valves can be provided with optional stem extensions to permit buried or underground installations in remote or inaccessible areas.

When used for buried valve service, they can be furnished "water-tight" and the piping of the grease injection system will also be extended.

When ordering extensions, please specify the distance required from the valve centerline to the handwheel centerline.

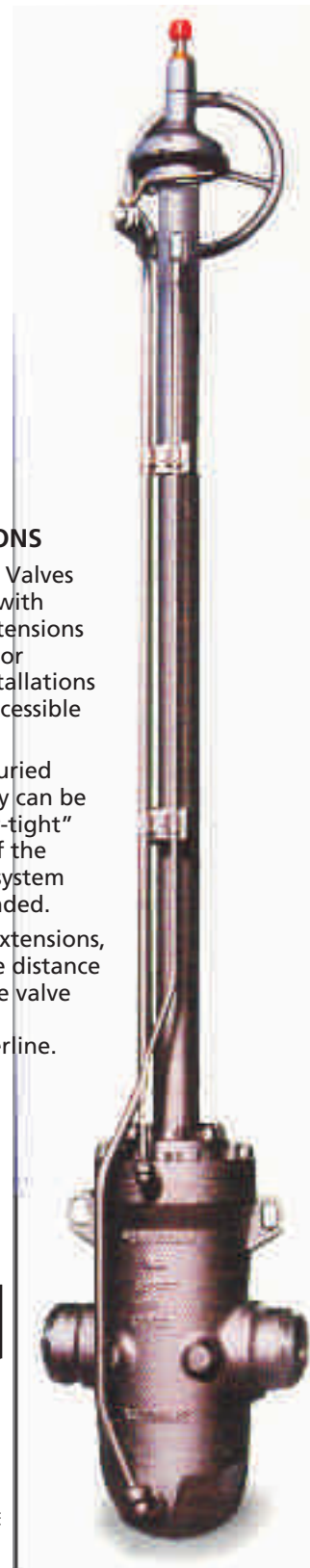

G12 OPTIONAL FEATURES

“REVERSE-ACTING” GATE DESIGN FOR FAIL TO CLOSE APPLICATIONS

GROVE’s standard design is a reverse acting fail-to-close design which prevents debris build-up in the valve body.

If the valve is normally open and “fail to close” is required, the valve can be supplied as “reverse acting” (gate moves upward to close).

“NORMAL-ACTING” GATE DESIGN FOR FAIL TO OPEN APPLICATIONS

If the valve is normally closed and “fail to open” is required, the valve can be supplied as “normal acting” (gate moves upward to open).

This type of design is typically utilized on Blow Down valves.

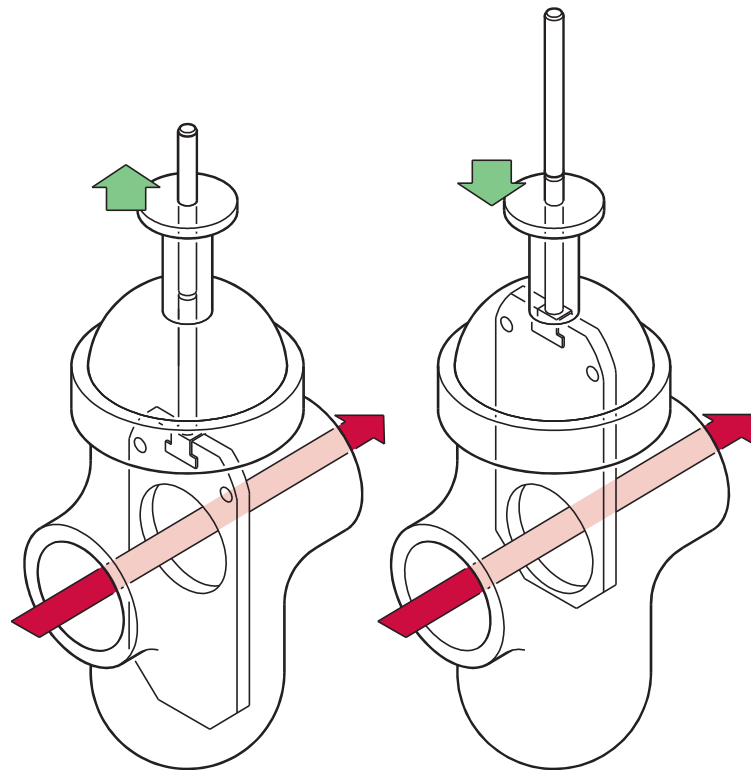

REVERSE ACTING

NORMAL ACTING

OUTSIDE STEM AND YOKE (OS&Y) BONNET AND BACK SEAT

GROVE G12 Gate Valves can be supplied with OS&Y bonnet design and back seat.

GROVE G12 Gate Valves with this bonnet design has the stem sealing injection system with a lantern ring in the middle of stem graphite packing.

When the valve is in back seat position the stem packing ring can be replaced with pressure in the body cavity.

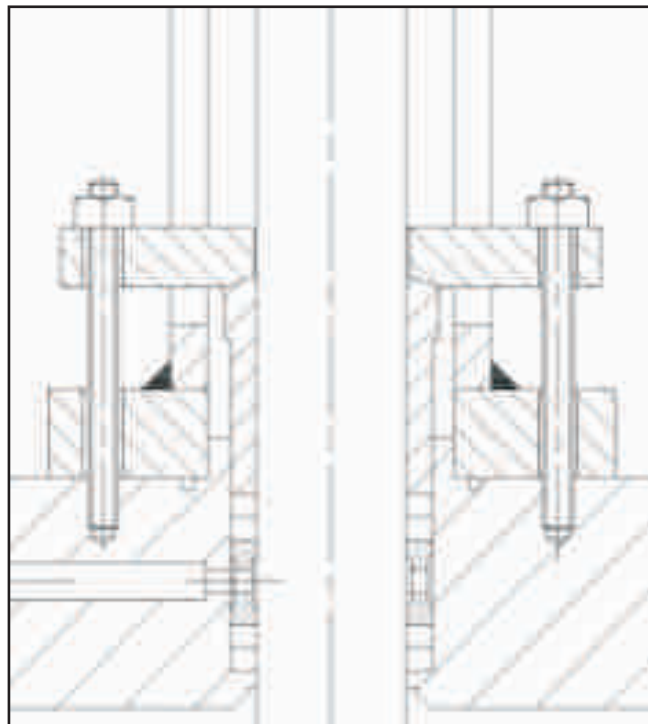

G12 SPECIAL APPLICATIONS

SEAT SKIRTS FOR DIRTY FLUID APPLICATION

GROVE G12 Gate Valves can be supplied with protection skirts when the valves are used in dirty fluid applications.

This feature is applicable to both gate normal acting design and gate reverse acting design.

The characteristic of GROVE skirts design allows for the use of a simple wedge tool for assembly and disassembly.

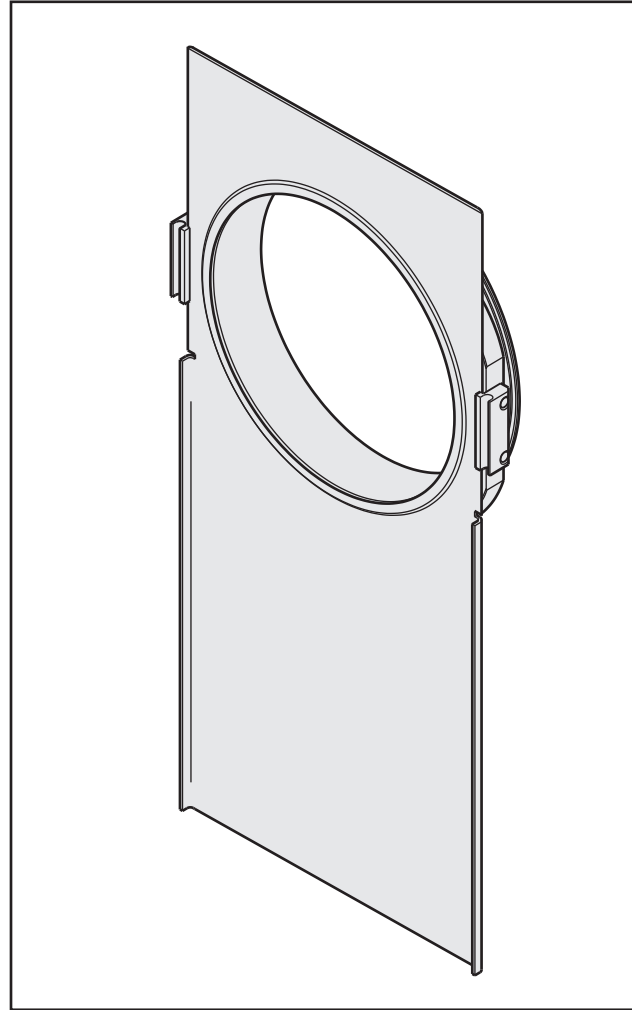

OPTIONAL SEAT DESIGN

Seat with plastic insert:

On request a thermo-plastic seal which seals between the seat and gate can be provided.

Seats with double piston effect design:

This seat design can be used in very critical service when the sealing system reliability has to be very high.

The design assures TRIPLE BARRIER from the upstream side to the down stream side of the valve; the DPE can be obtained on both O-ring and lip seal in the seal seat area. Usually in this type of valve the seal between the seats and gate is achieved using a Metal-to-Metal contact with Tungsten Carbide Coating (TCC).

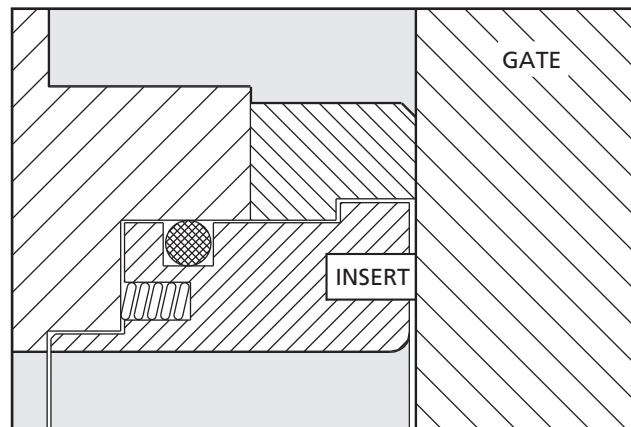

G12 SPECIAL APPLICATIONS

EMERGENCY SHUT DOWN VALVES (ESDV)

The GROVE G12 Gate Valve is subject to extremely stringent design criteria. Therefore, this valve is well suited for the severe requirements of Emergency Shut Down Valve (ESDV).

The valve is especially suited for adaptation with motor actuators using safety factors and test requirements to meet the most severe operating conditions.



G12 Gate Valve 42 inch ASME Class 1500 with hydraulic linear actuators

PLATING AND COATING TECHNOLOGIES

A range of coating and plating materials are available to suit specific service requirements for metal seated gate valves.

Tungsten Carbide powders applied with high velocity spray systems can be applied in-house using GROVE HVOF system.

Depending on service conditions Electroless Nickel Plating (ENP) can be applied in the hard version corresponding to ASTM B733.

The GROVE ENP process has been specially developed for valve applications and is applied using GROVE in-house plating facility.

Qualification testing can be performed at third party or GROVE's in-house facility.

VERTICAL INSTALLATION

A special version of the valve can be installed into vertical pipelines.

The valve is supplied together with special equipment that permits the gate and the seats to be removed while being supported during lateral disassembly.

METAL SEATED GATE VALVES

Service conditions

The selection of a metal seated valve is dependent on the service conditions such as:

- Abrasive fluids
- Service temperatures over the pressure/temperature ratings of the soft seat insert materials
- Service conditions requiring full reliability such as Emergency Shut Down Valves (ESDV).

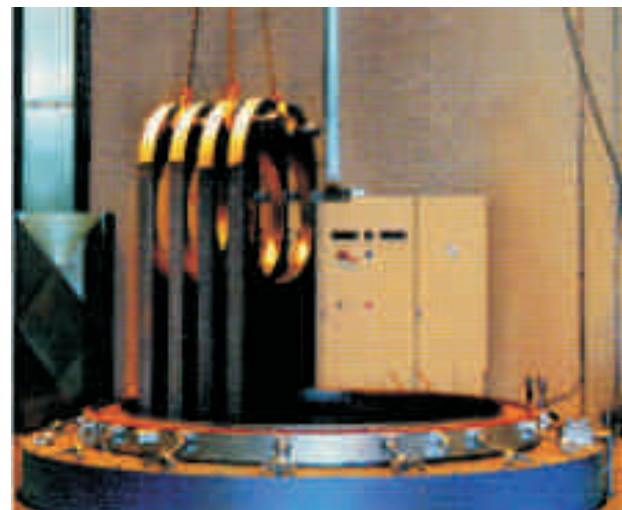

G12 MATERIALS SPECIFICATION

MATERIALS SELECTION

The GROVE G12 Gate Valve has been designed for use with various materials or combinations of materials which are dependent on the service conditions.

The following is a typical listing of materials for valves ASME Class 150-2500 for standard applications.

PRESSURE RETAINING PARTS

Body	A216 WCB, A216 WCC, A352 LCB, A352 LCC
Bonnet	A216 WCB, A216 WCC, A352 LCB, A352 LCC
Stem	AISI 4140 (Electroless Nickel Plated)
Bolting	A 193 B7, A 194 2H, A 193 B7M, A 194 2HM, A 320 L7, A 194 Gr.7, A 320 L7M, A 194 Gr. 7M

INTERNAL PARTS

Gate	A 572 Gr. 50 (eq. to Fe 510 EN 10025), P 355 NL2 - EN 10028
Seats	A105, A350 LF2
Springs	AISI 302, Inconel (different grades), Elgiloy

SEALING MATERIALS

Stem Gasket:	NBR (Nitrile) FKM (Viton different grades) HNBR (Hydrogenated Nitrile) Graphite packing (for OS&Y bonnet)
Seat/ Bonnet Gasket:	NBR (Nitrile) FKM (Viton different grades) HNBR (Hydrogenated Nitrile)

PLATING/COATING

0.001 inch	25 microns ENP Electroless Nickel Plating
0.003 inch	75 microns ENP Electroless Nickel Plating

NACE REQUIREMENTS

GROVE G12 Gate Valves can be supplied in accordance with the material requirements of ISO 15156/NACE MR0175

G12 VALVE ASSEMBLY

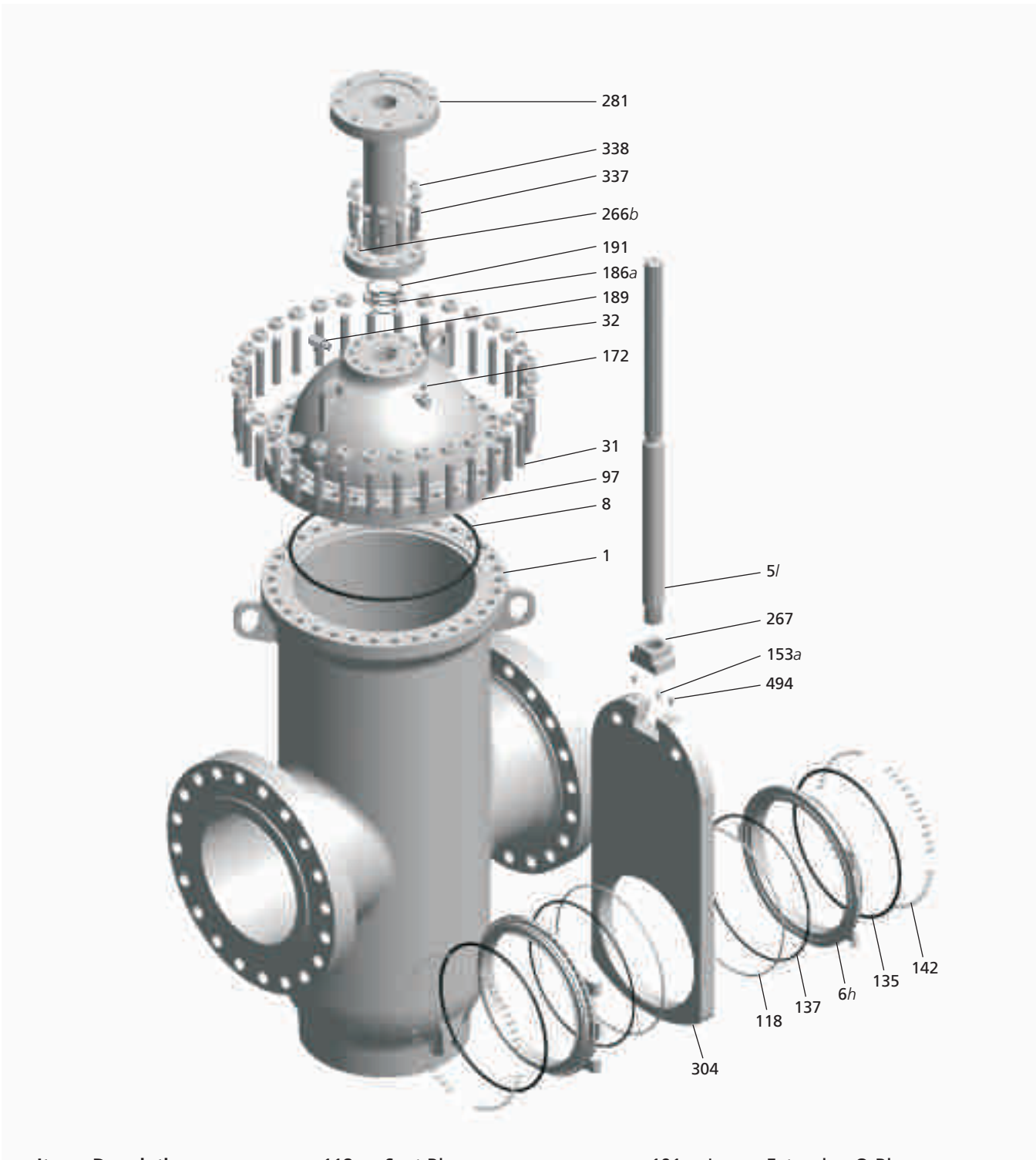

Item	Description	118	Seat Ring	191	Lower Extension O-Ring
1	Body	135	Seat Gasket O-Ring	266 <i>b</i>	Adapter Plate Stop Spring Pin
5/	Stem	137	Seal O-Ring	267	Stem Head
6 <i>h</i>	Seat	142	Cylindrical Spring	281	Yoke Unit
8	Body O-Ring	153 <i>a</i>	Driver Safety Pin	304	Gate
31	Body Stud	172	Vent Plug	337	Yoke Stud
32	Body Stud Nut	186 <i>a</i>	Stem Seal Gasket	338	Yoke Stud Nut
97	Bonnet	189	Stem Grease Fitting	494	Adjusting Screw

G12 ASME CLASS 150

Larger on request.
Reduced-bore valves
also available.

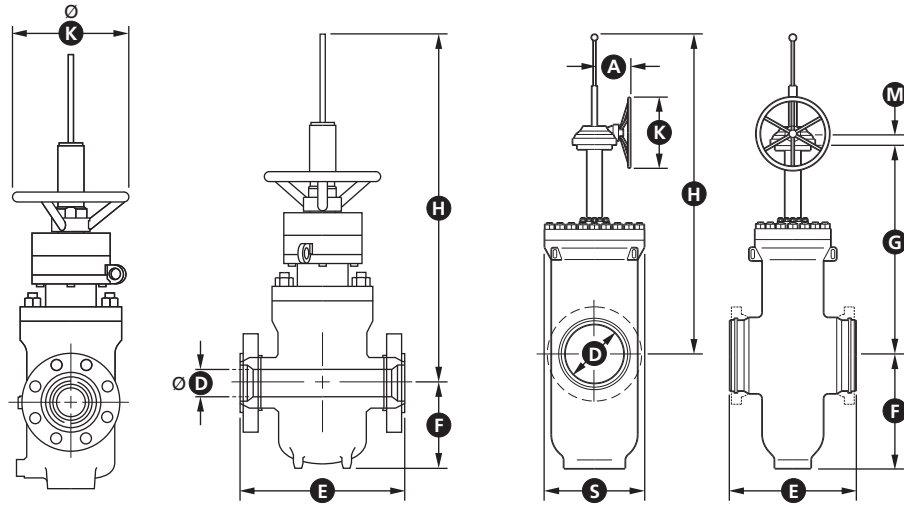

FROM 2 in. (50 mm) TO 14 in. (350 mm)

FROM 16 in. (400 mm) AND ABOVE

DIMENSIONS & WEIGHTS

SIZE in. (mm)	D	E			F	G	S	H	A	K	M	WEIGHT lb. (kg)	
		WE	RF	RTJ								WE	RF/RTJ
2 (50)	2 (51)	8 1/2 (216)	7 (178)	7 1/2 (191)	5 3/8 (137)	-	-	20 1/2 (520)	-	-	-	-	75 (34)
3 (80)	3 (76)	11 (283)	8 (203)	8 1/2 (216)	7 (180)	-	-	23 5/8 (600)	-	-	-	-	115 (52)
4 (100)	4 (102)	12 (305)	9 (229)	9 1/2 (241)	8 5/8 (220)	-	-	24 3/8 (620)	-	-	-	-	179 (81)
6 (150)	6 (152)	15 7/8 (403)	10 1/2 (267)	11 (279)	13 1/4 (338)	24 5/8 (626)	13 3/4 (348)	43 1/8 (1094)	7 7/8 (200)	11 3/4 (300)	2 1/4 (56)	349 (158)	397 (180)
8 (200)	8 (203)	16 1/2 (419)	11 1/2 (292)	12 (305)	16 1/4 (412)	31 1/4 (794)	15 3/8 (390)	55 1/2 (1409)	7 7/8 (200)	11 3/4 (300)	2 1/4 (56)	582 (264)	661 (300)
10 (250)	10 (254)	18 (457)	13 (330)	13 1/2 (343)	19 1/2 (495)	37 (941)	17 3/4 (451)	63 7/8 (1624)	7 7/8 (200)	11 3/4 (300)	2 1/4 (56)	638 (290)	725 (329)
12 (300)	12 (305)	19 3/4 (502)	14 (356)	14 1/2 (368)	22 1/2 (570)	42 1/4 (1073)	21 (533)	73 1/2 (1868)	7 7/8 (200)	11 3/4 (300)	2 1/4 (56)	883 (400)	1003 (455)
14 (350)	13 1/4 (337)	22 1/2 (572)	15 (381)	15 1/2 (394)	25 1/8 (638)	45 1/2 (1156)	22 (560)	79 1/8 (2010)	7 7/8 (200)	11 3/4 (300)	2 1/4 (56)	1365 (619)	1551 (704)
16 (400)	15 1/4 (387)	24 (610)	16 (406)	16 1/2 (419)	28 1/8 (715)	51 3/4 (1315)	23 7/8 (608)	90 3/8 (2297)	7 7/8 (200)	11 3/4 (300)	2 1/4 (56)	1915 (869)	2176 (987)
18 (450)	17 1/4 (438)	26 (660)	17 (432)	17 1/2 (445)	31 1/2 (800)	58 1/4 (1480)	26 3/4 (680)	101 5/8 (2580)	7 7/8 (200)	11 3/4 (300)	2 1/4 (56)	2458 (1115)	2793 (1267)
20 (500)	19 1/4 (489)	28 (711)	18 (457)	18 1/2 (470)	34 5/8 (880)	64 1/8 (1630)	29 1/8 (740)	111 (2820)	7 7/8 (200)	11 3/4 (300)	2 1/4 (56)	3164 (1435)	3596 (1631)
22 (550)	21 1/4 (540)	*	*	*	37 3/4 (960)	69 1/4 (1760)	31 1/2 (800)	120 1/2 (3060)	8 5/8 (220)	19 5/8 (500)	2 7/8 (74)	4061 (1842)	4614 (2093)
24 (600)	23 1/4 (591)	32 (813)	20 (508)	20 1/2 (521)	41 7/8 (1065)	73 1/2 (1867)	33 1/2 (852)	128 7/8 (3273)	8 5/8 (220)	19 5/8 (500)	2 7/8 (74)	5093 (2310)	5787 (2625)
26 (650)	25 (635)	34 (864)	22 (559)	*	43 3/4 (1110)	80 3/8 (2040)	36 1/4 (920)	139 3/8 (3540)	8 5/8 (220)	19 5/8 (500)	2 7/8 (74)	5948 (2698)	6759 (3066)
28 (700)	27 (686)	36 (914)	24 (610)	*	46 7/8 (1190)	85 7/8 (2180)	38 1/4 (970)	148 7/8 (3780)	9 1/2 (241)	19 5/8 (500)	3 5/8 (92)	7062 (3203)	8025 (3640)
30 (750)	29 (737)	36 (914)	26 (660)	*	49 5/8 (1260)	91 3/8 (2320)	40 1/2 (1030)	157 1/2 (4000)	9 1/2 (241)	19 5/8 (500)	3 5/8 (92)	8298 (3764)	9429 (4277)
32 (800)	30 3/4 (781)	38 (965)	28 (711)	*	52 3/4 (1340)	96 1/2 (2450)	42 1/2 (1080)	167 3/8 (4250)	12 5/8 (320)	19 5/8 (500)	4 (102)	10009 (4540)	11374 (5159)
34 (850)	32 3/4 (832)	40 (1016)	30 (762)	*	55 7/8 (1420)	102 3/8 (2600)	44 7/8 (1140)	177 1/8 (4500)	12 5/8 (320)	19 5/8 (500)	4 (102)	11924 (5408)	13549 (6146)
36 (900)	34 1/2 (876)	40 (1016)	32 (813)	*	58 5/8 (1490)	107 7/8 (2740)	47 1/4 (1200)	186 1/4 (4730)	12 5/8 (320)	19 5/8 (500)	4 (102)	13689 (6209)	15556 (7056)
38 (950)	36 1/2 (927)	*	*	*	61 3/4 (1570)	113 (2870)	49 5/8 (1260)	195 1/4 (4960)	12 5/8 (320)	19 5/8 (500)	4 (102)	14938 (6776)	16975 (7700)
40 (1000)	38 1/2 (978)	*	*	*	65 (1650)	118 7/8 (3020)	52 (1320)	204 3/4 (5200)	12 5/8 (320)	19 5/8 (500)	4 (102)	16079 (7293)	18272 (8288)
42 (1050)	40 1/4 (1022)	*	*	*	68 1/8 (1730)	124 3/8 (3160)	53 7/8 (1370)	214 5/8 (5450)	16 1/8 (410)	31 1/2 (800)	4 1/2 (115)	19773 (8969)	22469 (10192)
48 (1200)	46 (1168)	*	*	*	76 3/4 (1950)	141 (3580)	61 (1550)	242 7/8 (6170)	16 1/8 (410)	31 1/2 (800)	4 1/2 (115)	26427 (11987)	30031 (13622)
54 (1350)	51 3/4 (1314)	*	*	*	86 1/4 (2190)	157 1/2 (4000)	67 3/4 (1720)	270 7/8 (6880)	17 7/8 (453)	31 1/2 (800)	5 7/8 (150)	32593 (14784)	37037 (16800)
56 (1400)	53 3/4 (1365)	*	*	*	89 (2260)	163 3/8 (4150)	69 5/8 (1770)	280 3/4 (7130)	17 7/8 (453)	31 1/2 (800)	5 7/8 (150)	35309 (16016)	40124 (18200)
60 (1500)	57 1/2 (1461)	*	*	*	94 7/8 (2410)	173 1/4 (4400)	74 (1880)	299 1/4 (7600)	19 5/8 (500)	31 1/2 (800)	6 1/8 (155)	40741 (18480)	46297 (21000)

* Upon Request

Flanges up to 24 in. (600 mm) (except 22 in. (550 mm)) in accordance with ASME B16.5;
22 in. (550 mm) and above 24 in. (600 mm) in accordance with MSS-SP-44 if applicable.

Shaded Dimensions in accordance to ISO 14313
Butt Welding Ends according to ASME B16.25

G12 ASME CLASS 300

Larger on request.
Reduced-bore valves
also available.

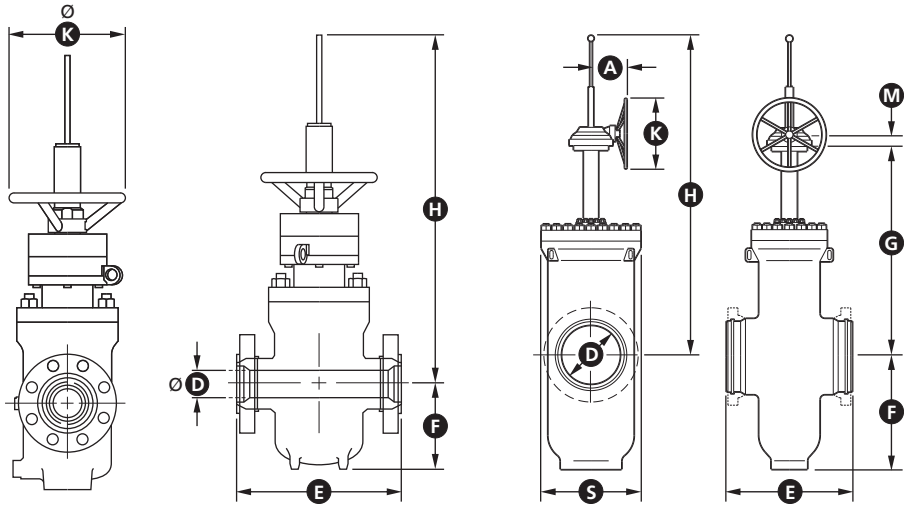

DIMENSIONS & WEIGHTS

FROM 2 in. (50 mm) TO 8 in. (200 mm)

FROM 10 in. (250 mm) AND ABOVE

SIZE in. (mm)	D	E			F	G	S	H	A	K	M	WEIGHT lb. (kg)	
		WE	RF	RTJ								WE	RF/RTJ
2 (50)	2 (51)	8 1/2 (216)	8 1/2 (261)	9 1/8 (232)	5 3/8 (137)	-	-	20 1/2 (520)	-	-	-	-	104 (47)
3 (80)	3 (76)	11 (283)	11 (283)	11 3/4 (298)	7 (180)	-	-	23 5/8 (600)	-	9 7/8 (250)	-	-	137 (62)
4 (100)	4 (102)	12 (305)	12 (305)	12 5/8 (321)	8 5/8 (220)	-	-	24 3/8 (620)	-	11 3/4 (300)	-	-	198 (90)
6 (150)	6 (152)	15 7/8 (403)	15 7/8 (403)	16 1/2 (419)	15 3/8 (392)	26 1/4 (666)	12 3/8 (314)	43 1/8 (1096)	7 7/8 (200)	11 3/4 (300)	2 1/4 (56)	351 (159)	397 (180)
8 (200)	8 (203)	16 1/2 (419)	16 1/2 (419)	17 1/8 (435)	16 7/8 (430)	31 3/4 (806)	15 1/8 (385)	54 (1372)	7 7/8 (200)	11 3/4 (300)	2 1/4 (56)	586 (266)	661 (300)
10 (250)	10 (254)	18 (457)	18 (457)	18 5/8 (473)	22 (559)	37 (941)	17 3/4 (451)	64 7/8 (1646)	7 7/8 (200)	11 3/4 (300)	2 1/4 (56)	918 (416)	1036 (470)
12 (300)	12 (305)	19 3/4 (502)	19 3/4 (502)	20 3/8 (518)	25 1/8 (637)	42 1/2 (1078)	20 1/2 (519)	73 3/4 (1872)	7 7/8 (200)	11 3/4 (300)	2 1/4 (56)	1269 (576)	1433 (650)
14 (350)	13 1/4 (337)	30 (762)	30 (762)	30 5/8 (778)	28 1/2 (725)	48 1/4 (1225)	22 3/8 (568)	83 (2107)	8 5/8 (220)	19 5/8 (500)	2 7/8 (74)	1962 (890)	2216 (1005)
16 (400)	15 1/4 (387)	33 (838)	33 (838)	33 5/8 (854)	30 7/8 (784)	54 (1372)	25 7/8 (657)	92 5/8 (2352)	8 5/8 (220)	19 5/8 (500)	2 7/8 (74)	2778 (1260)	3108 (1410)
18 (450)	17 1/4 (438)	36 (914)	36 (914)	36 5/8 (930)	33 5/8 (853)	59 3/4 (1519)	28 1/8 (715)	102 5/8 (2607)	9 1/2 (241)	19 5/8 (500)	3 5/8 (92)	3571 (1620)	3990 (1810)
20 (500)	19 1/4 (489)	39 (991)	39 (991)	39 3/4 (1010)	33 7/8 (860)	64 7/8 (1646)	32 1/8 (815)	111 7/8 (2842)	9 1/2 (241)	19 5/8 (500)	3 5/8 (92)	4652 (2110)	5137 (2330)
22 (550)	21 1/4 (540)	43 (1092)	43 (1092)	43 7/8 (1114)	40 1/8 (1019)	71 3/8 (1813)	33 5/8 (853)	121 7/8 (3097)	9 1/2 (241)	19 5/8 (500)	3 5/8 (92)	5997 (2720)	6592 (2990)
24 (600)	23 1/4 (591)	45 (1143)	45 (1143)	45 7/8 (1165)	43 1/4 (1098)	76 (1931)	36 1/4 (921)	131 1/8 (3332)	12 5/8 (320)	19 5/8 (500)	4 (102)	7518 (3410)	8267 (3750)
26 (650)	25 (635)	49 (1245)	49 (1245)	50 (1270)	46 1/4 (1176)	81 3/4 (2078)	38 5/8 (980)	140 7/8 (3577)	12 5/8 (320)	19 5/8 (500)	4 (102)	8752 (3970)	9656 (4380)
28 (700)	27 (686)	53 (1346)	53 (1346)	54 (1372)	48 5/8 (1235)	87 1/4 (2215)	42 7/8 (1088)	150 7/8 (3832)	16 1/8 (410)	31 1/2 (800)	4 1/2 (115)	10394 (4715)	11464 (5200)
30 (750)	29 (737)	55 (1397)	55 (1397)	56 (1422)	52 1/8 (1323)	92 5/8 (2352)	44 3/8 (1127)	160 1/8 (4067)	16 1/8 (410)	31 1/2 (800)	4 1/2 (115)	12213 (5540)	13470 (6110)
32 (800)	30 3/4 (781)	60 (1524)	60 (1524)	61 1/8 (1553)	55 (1397)	98 3/8 (2499)	45 3/4 (1161)	170 1/8 (4322)	16 1/8 (410)	31 1/2 (800)	4 1/2 (115)	14749 (6690)	16248 (7370)
34 (850)	32 3/4 (832)	64 (1626)	64 (1626)	65 1/8 (1654)	58 1/4 (1480)	104 1/8 (2646)	49 3/8 (1254)	181 3/8 (4606)	16 1/8 (410)	31 1/2 (800)	4 1/2 (115)	17703 (8030)	19356 (8780)
36 (900)	34 1/2 (876)	68 (1727)	68 (1727)	69 1/8 (1756)	61 3/4 (1568)	110 (2793)	52 1/8 (1323)	189 1/2 (4812)	17 7/8 (453)	31 1/2 (800)	5 7/8 (150)	20348 (9230)	22222 (10080)
38 (950)	36 1/2 (927)	*	*	*	64 7/8 (1646)	115 3/4 (2940)	54 3/4 (1392)	200 1/4 (5086)	17 7/8 (453)	31 1/2 (800)	5 7/8 (150)	23083 (10470)	24251 (11000)
40 (1000)	38 1/2 (978)	*	*	*	66 3/8 (1686)	121 1/8 (3077)	56 (1421)	208 (5282)	17 7/8 (453)	31 1/2 (800)	5 7/8 (150)	24846 (11270)	26102 (11840)
42 (1050)	40 1/4 (1022)	*	*	*	70 5/8 (1793)	126 1/2 (3214)	60 1/4 (1529)	218 3/8 (5547)	17 7/8 (453)	31 1/2 (800)	5 7/8 (150)	30710 (13930)	32099 (14560)
48 (1200)	46 (1168)	*	*	*	80 1/4 (2038)	143 1/2 (3646)	67 1/8 (1705)	248 1/8 (6301)	26 (660)	31 1/2 (800)	8 1/2 (215)	41160 (18670)	42902 (19460)
54 (1350)	51 3/4 (1314)	*	*	*	89 1/8 (2264)	160 7/8 (4087)	76 (1931)	278 1/8 (7066)	26 (660)	31 1/2 (800)	8 1/2 (215)	50762 (23026)	52910 (24000)
56 (1400)	53 3/4 (1365)	*	*	*	92 5/8 (2352)	165 7/8 (4214)	78 3/4 (1999)	285 1/8 (7242)	26 (660)	31 1/2 (800)	8 1/2 (215)	54993 (24945)	57320 (26000)
60 (1500)	57 1/2 (1461)	*	*	*	98 3/8 (2499)	177 1/2 (4508)	84 1/8 (2136)	305 1/4 (7752)	-	-	-	63453 (28782)	66138 (30000)

* Upon Request

Flanges up to 24 in. (600 mm) (except 22 in. (550 mm)) in accordance with ASME B16.5;
22 in. (550 mm) and above 24 in. (600 mm) in accordance with MSS-SP-44 if applicable.

Shaded Dimensions in accordance to ISO 14313
Butt Welding Ends according to ASME B16.25

G12 ASME CLASS 400

Larger on request.
Reduced-bore valves
also available.

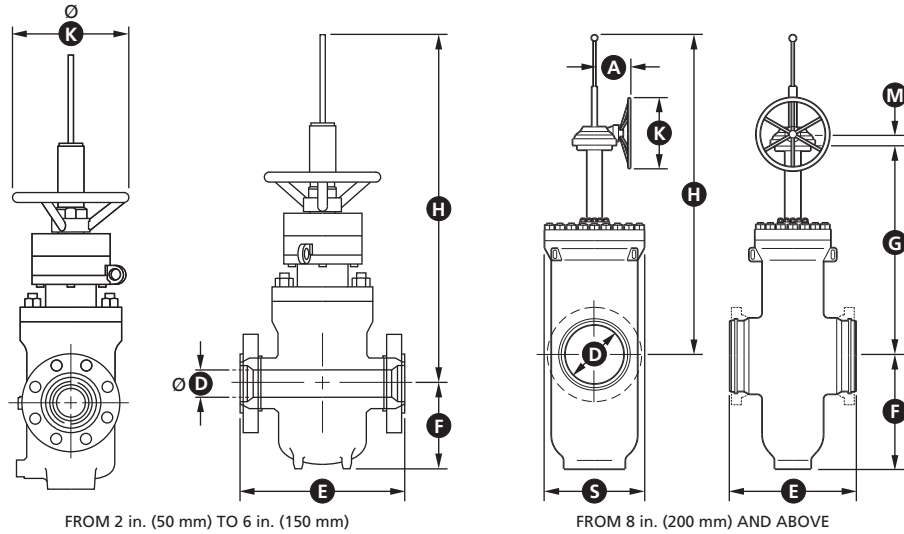

DIMENSIONS & WEIGHTS

SIZE in. (mm)	D	E			F	G	S	H	A	K	M	WEIGHT lb. (kg)	
		WE	RF	RTJ								WE	RF/RTJ
2 (50)	2 (51)	11 1/2 (292)	11 1/2 (292)	11 5/8 (295)	5 3/8 (137)	-	-	21 5/8 (550)	-	9 7/8 (250)	-	-	137 (62)
3 (80)	3 (76)	14 (356)	14 (356)	14 1/8 (359)	7 1/4 (184)	-	-	26 (660)	-	11 3/4 (300)	-	-	220 (100)
4 (100)	4 (102)	17 (432)	17 (432)	17 1/8 (435)	11 5/8 (295)	-	-	30 (760)	-	13 3/4 (350)	-	-	375 (170)
6 (150)	6 (152)	19 1/2 (495)	19 1/2 (495)	19 5/8 (498)	15 3/4 (400)	26 3/4 (680)	12 5/8 (320)	44 (1118)	7 7/8 (200)	11 3/4 (300)	2 1/4 (56)	463 (210)	529 (240)
8 (200)	8 (203)	23 1/2 (597)	23 1/2 (597)	23 5/8 (600)	18 7/8 (480)	31 7/8 (810)	15 3/8 (390)	55 1/8 (1400)	7 7/8 (200)	11 3/4 (300)	2 1/4 (56)	750 (340)	849 (385)
10 (250)	10 (254)	26 1/2 (673)	26 1/2 (673)	26 5/8 (676)	22 1/2 (570)	37 3/4 (960)	18 1/8 (460)	66 1/8 (1680)	7 7/8 (200)	11 3/4 (300)	2 1/4 (56)	1113 (505)	1246 (565)
12 (300)	12 (305)	30 (762)	30 (762)	30 1/8 (765)	25 5/8 (650)	43 1/4 (1100)	20 7/8 (530)	75 1/4 (1910)	8 5/8 (220)	19 5/8 (500)	2 7/8 (74)	1499 (680)	1687 (765)
14 (350)	13 1/4 (337)	32 1/2 (826)	32 1/2 (826)	32 5/8 (829)	29 1/8 (740)	49 1/4 (1250)	22 7/8 (580)	84 5/8 (2150)	8 5/8 (220)	19 5/8 (500)	2 7/8 (74)	2227 (1010)	2491 (1130)
16 (400)	15 1/4 (387)	35 1/2 (902)	35 1/2 (902)	35 5/8 (905)	31 1/2 (800)	55 1/8 (1400)	26 3/8 (670)	94 1/2 (2400)	8 5/8 (220)	19 5/8 (500)	2 7/8 (74)	3153 (1430)	3483 (1580)
18 (450)	17 1/4 (438)	38 1/2 (978)	38 1/2 (978)	38 5/8 (981)	34 1/4 (870)	61 (1550)	28 3/4 (730)	104 3/4 (2660)	9 1/2 (241)	19 5/8 (500)	3 5/8 (92)	4277 (1940)	4674 (2120)
20 (500)	19 1/4 (489)	41 1/2 (1054)	41 1/2 (1054)	41 3/4 (1060)	34 5/8 (878)	66 1/8 (1680)	32 3/4 (832)	114 1/8 (2900)	12 5/8 (320)	19 5/8 (500)	4 (102)	5512 (2500)	6063 (2750)
22 (550)	21 1/4 (540)	45 (1143)	45 (1143)	45 3/8 (1153)	41 (1040)	72 7/8 (1850)	34 1/4 (870)	124 3/8 (3160)	12 5/8 (320)	19 5/8 (500)	4 (102)	6393 (2900)	6989 (3170)
24 (600)	23 1/4 (591)	48 1/2 (1232)	48 1/2 (1232)	48 7/8 (1241)	44 1/8 (1120)	77 1/2 (1970)	37 (940)	133 7/8 (3400)	12 5/8 (320)	19 5/8 (500)	4 (102)	8179 (3710)	8929 (4050)
26 (650)	25 (635)	51 1/2 (1308)	51 1/2 (1308)	52 (1321)	47 1/4 (1200)	83 1/2 (2120)	39 3/8 (1000)	143 3/4 (3650)	16 1/8 (410)	31 1/2 (800)	4 1/2 (115)	9458 (4290)	10362 (4700)
28 (700)	27 (686)	55 (1397)	55 (1397)	55 1/2 (1410)	49 5/8 (1260)	89 (2260)	43 3/4 (1110)	153 7/8 (3910)	16 1/8 (410)	31 1/2 (800)	4 1/2 (115)	11243 (5100)	12566 (5700)
30 (750)	29 (737)	60 (1524)	60 (1524)	60 1/2 (1537)	53 1/8 (1350)	94 1/2 (2400)	45 1/4 (1150)	163 3/8 (4150)	17 7/8 (453)	31 1/2 (800)	5 7/8 (150)	13713 (6220)	14947 (6780)
32 (800)	30 3/4 (781)	65 (1651)	65 (1651)	65 5/8 (1667)	56 1/8 (1425)	100 3/8 (2550)	46 5/8 (1185)	173 5/8 (4410)	17 7/8 (453)	31 1/2 (800)	5 7/8 (150)	15256 (6920)	16639 (7547)
34 (850)	32 3/4 (832)	70 (1778)	70 (1778)	70 5/8 (1794)	59 1/2 (1510)	106 1/4 (2700)	50 3/8 (1280)	185 (4700)	17 7/8 (453)	31 1/2 (800)	5 7/8 (150)	19246 (8730)	20900 (9480)
36 (900)	34 1/2 (876)	74 (1880)	74 (1880)	74 5/8 (1895)	63 (1600)	112 1/4 (2850)	53 1/8 (1350)	193 1/4 (4910)	19 5/8 (500)	31 1/2 (800)	6 1/8 (155)	21605 (9800)	23369 (10600)
38 (950)	36 1/2 (927)	*	*	*	66 1/8 (1680)	118 1/8 (3000)	55 7/8 (1420)	204 3/8 (5190)	19 5/8 (500)	31 1/2 (800)	6 1/8 (155)	26455 (12000)	27998 (12700)
40 (1000)	38 1/2 (978)	*	*	*	67 3/4 (1720)	123 5/8 (3140)	57 1/8 (1450)	212 1/4 (5390)	19 5/8 (500)	31 1/2 (800)	6 1/8 (155)	29542 (13400)	30864 (14000)
42 (1050)	40 1/4 (1022)	*	*	*	72 (1830)	129 1/8 (3280)	61 3/8 (1560)	222 7/8 (5660)	19 5/8 (500)	31 1/2 (800)	6 1/8 (155)	33730 (15300)	35053 (15900)
48 (1200)	46 (1168)	*	*	*	81 7/8 (2080)	146 1/2 (3720)	68 1/2 (1740)	253 1/8 (6430)	26 (660)	31 1/2 (800)	8 1/2 (215)	45635 (20700)	47399 (21500)
54 (1350)	51 3/4 (1314)	*	*	*	91 (2310)	164 1/8 (4170)	77 1/2 (1970)	283 7/8 (7210)	-	-	-	57320 (26000)	61729 (28000)
56 (1400)	53 3/4 (1365)	*	*	*	94 1/2 (2400)	169 1/4 (4300)	80 3/8 (2040)	291 (7390)	-	-	-	61729 (28000)	66138 (30000)
60 (1500)	57 1/2 (1461)	*	*	*	100 3/8 (2550)	181 1/8 (4600)	85 7/8 (2180)	311 3/8 (7910)	-	-	-	70547 (32000)	74956 (34000)

* Upon Request

Flanges up to 24 in. (600 mm) (except 22 in. (550 mm)) in accordance with ASME B16.5;
22 in. (550 mm) and above 24 in. (600 mm) in accordance with MSS-SP-44 if applicable.

Shaded Dimensions in accordance to ISO 14313
Butt Welding Ends according to ASME B16.25

G12 ASME CLASS 600

Larger on request.
Reduced-bore valves
also available.

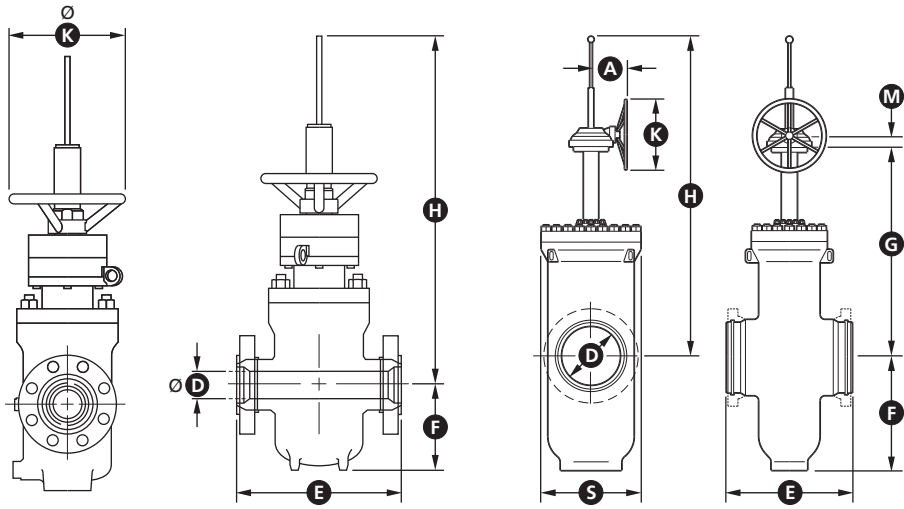

DIMENSIONS & WEIGHTS

FROM 2 in. (50 mm) TO 6 in. (150 mm)

FROM 8 in. (200 mm) AND ABOVE

SIZE in. (mm)	D	E			F	G	S	H	A	K	M	WEIGHT lb. (kg)	
		WE	RF	RTJ								WE	RF/RTJ
2 (50)	2 (51)	11 1/2 (292)	11 1/2 (292)	11 5/8 (295)	5 3/8 (137)	-	-	21 5/8 (550)	-	9 7/8 (250)	-	-	137 (62)
3 (80)	3 (76)	14 (356)	14 (356)	14 1/8 (359)	7 1/4 (184)	-	-	26 (660)	-	11 3/4 (300)	-	-	220 (100)
4 (100)	4 (102)	17 (432)	17 (432)	17 1/8 (435)	11 5/8 (295)	-	-	30 (760)	-	13 3/4 (350)	-	-	375 (170)
6 (150)	6 (152)	22 (559)	22 (559)	22 1/8 (562)	14 1/8 (359)	24 3/4 (630)	13 (330)	44 (1118)	7 7/8 (200)	11 3/4 (300)	2 1/4 (56)	566 (257)	679 (308)
8 (200)	8 (203)	26 (660)	26 (660)	26 1/8 (664)	16 5/8 (421)	31 3/4 (808)	15 3/8 (392)	55 3/8 (1406)	7 7/8 (200)	11 3/4 (300)	2 1/4 (56)	903 (410)	1067 (484)
10 (250)	10 (254)	31 (787)	31 (787)	31 1/8 (791)	20 3/8 (517)	38 1/4 (970)	17 7/8 (455)	65 7/8 (1672)	8 5/8 (220)	19 5/8 (500)	2 7/8 (74)	1321 (599)	1587 (720)
12 (300)	12 (305)	33 (838)	33 (838)	33 1/8 (841)	23 1/4 (590)	43 3/8 (1103)	20 1/8 (511)	76 (1929)	8 5/8 (220)	19 5/8 (500)	2 7/8 (74)	2196 (996)	2557 (1160)
14 (350)	13 1/4 (337)	35 (889)	35 (889)	35 1/8 (892)	29 1/8 (740)	47 3/4 (1214)	22 7/8 (580)	82 5/8 (2100)	9 1/2 (241)	19 5/8 (500)	3 5/8 (92)	3163 (1435)	3571 (1620)
16 (400)	15 1/4 (387)	39 (991)	39 (991)	39 1/8 (994)	31 1/2 (800)	53 (1345)	26 1/2 (674)	92 1/2 (2349)	12 5/8 (320)	19 5/8 (500)	4 (102)	3512 (1593)	3968 (1800)
18 (450)	17 1/4 (438)	43 (1092)	43 (1092)	43 1/8 (1095)	33 1/2 (850)	58 7/8 (1496)	29 3/8 (746)	102 7/8 (2613)	12 5/8 (320)	19 5/8 (500)	4 (102)	4806 (2180)	5379 (2440)
20 (500)	19 1/4 (489)	47 (1194)	47 (1194)	47 1/4 (1200)	37 3/8 (950)	65 3/4 (1671)	32 3/4 (832)	114 5/8 (2911)	12 5/8 (320)	19 5/8 (500)	4 (102)	5822 (2641)	6581 (2985)
22 (550)	21 1/4 (540)	51 (1295)	51 (1295)	51 3/8 (1305)	39 5/8 (1006)	72 (1830)	34 7/8 (885)	126 1/2 (3213)	16 1/8 (410)	31 1/2 (800)	4 1/2 (115)	7209 (3270)	8400 (3810)
24 (600)	23 1/4 (591)	55 (1397)	55 (1397)	55 3/8 (1407)	45 1/4 (1150)	79 1/2 (2020)	39 (990)	138 1/4 (3510)	16 1/8 (410)	31 1/2 (800)	4 1/2 (115)	9348 (4240)	10450 (4740)
26 (650)	25 (635)	57 (1448)	57 (1448)	57 1/2 (1461)	48 3/8 (1230)	86 1/4 (2190)	41 3/8 (1050)	146 1/8 (3710)	17 7/8 (453)	31 1/2 (800)	5 7/8 (150)	11001 (4990)	12346 (5600)
28 (700)	27 (686)	61 (1549)	61 (1549)	61 1/2 (1562)	51 5/8 (1310)	92 1/2 (2350)	44 1/2 (1130)	153 1/8 (3890)	17 7/8 (453)	31 1/2 (800)	5 7/8 (150)	13228 (6000)	14991 (6800)
30 (750)	29 (737)	65 (1651)	65 (1651)	65 1/2 (1664)	57 1/8 (1450)	97 7/8 (2487)	47 1/4 (1200)	169 1/4 (4298)	19 5/8 (500)	31 1/2 (800)	6 1/8 (155)	15851 (7190)	17549 (7960)
32 (800)	30 3/4 (781)	70 (1778)	70 (1778)	70 5/8 (1794)	59 (1500)	104 3/8 (2650)	50 3/8 (1280)	177 1/2 (4510)	19 5/8 (500)	31 1/2 (800)	6 1/8 (155)	18849 (8550)	20745 (9410)
34 (850)	32 3/4 (832)	76 (1930)	76 (1930)	76 5/8 (1946)	62 1/4 (1580)	110 1/4 (2800)	53 1/8 (1350)	189 (4800)	19 5/8 (500)	31 1/2 (800)	6 1/8 (155)	22707 (10300)	24692 (11200)
36 (900)	34 1/2 (876)	82 (2083)	82 (2083)	82 5/8 (2099)	65 1/2 (1663)	114 5/8 (2910)	55 1/8 (1401)	197 7/8 (5026)	26 (660)	31 1/2 (800)	8 1/2 (215)	26014 (11800)	28439 (12900)
38 (950)	36 1/2 (927)	*	*	*	68 7/8 (1750)	122 (3100)	58 1/4 (1480)	207 7/8 (5280)	26 (660)	31 1/2 (800)	8 1/2 (215)	30864 (14000)	33069 (15000)
40 (1000)	38 1/2 (978)	*	*	*	72 (1830)	128 3/8 (3260)	61 (1550)	216 1/2 (5500)	26 (660)	31 1/2 (800)	8 1/2 (215)	34612 (15700)	36596 (16600)
42 (1050)	40 1/4 (1022)	*	*	*	75 5/8 (1920)	133 7/8 (3400)	63 3/4 (1620)	224 3/4 (5710)	-	-	-	39683 (18000)	42328 (19200)
48 (1200)	46 (1168)	*	*	*	85 3/8 (2170)	152 3/8 (3870)	72 1/2 (1840)	255 1/2 (6490)	-	-	-	54674 (24800)	57981 (26300)
54 (1350)	51 3/4 (1314)	*	*	*	96 1/2 (2450)	171 1/4 (4350)	80 3/4 (2050)	285 7/8 (7260)	-	-	-	68343 (31000)	77161 (35000)
56 (1400)	53 3/4 (1365)	*	*	*	99 1/4 (2520)	177 1/8 (4500)	83 1/2 (2120)	295 5/8 (7510)	-	-	-	72752 (33000)	83775 (38000)
60 (1500)	57 1/2 (1461)	*	*	*	106 1/4 (2700)	189 (4800)	89 (2260)	315 3/8 (8010)	-	-	-	81570 (37000)	99207 (45000)

* Upon Request

Flanges up to 24 in. (600 mm) (except 22 in. (550 mm)) in accordance with ASME B16.5;
22 in. (550 mm) and above 24 in. (600 mm) in accordance with MSS-SP-44 if applicable.

Shaded Dimensions in accordance with ISO 14313
Butt Welding Ends according to ASME B16.25

G12

ASME CLASS 900

Larger on request.
Reduced-bore valves
also available.

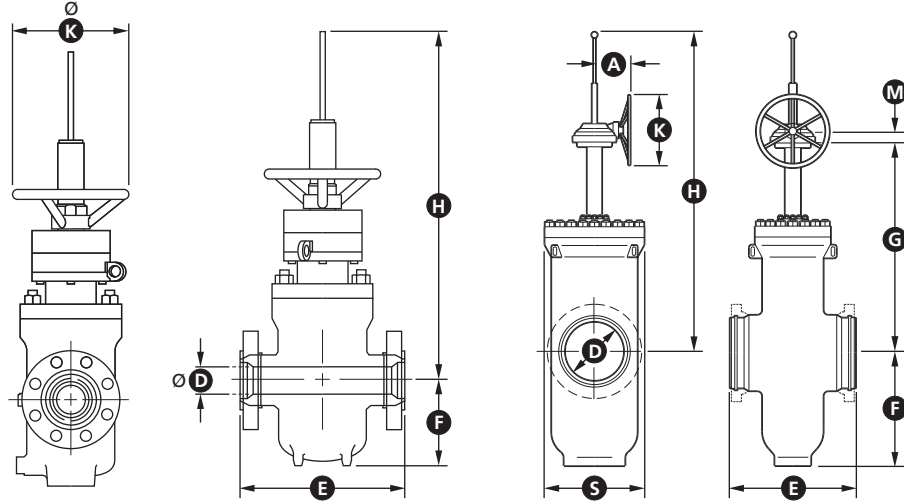

FROM 2 in. (50 mm) TO 4 in. (100 mm)

FROM 6 in. (150 mm) AND ABOVE

DIMENSIONS & WEIGHTS

SIZE in. (mm)	D	E			F	G	S	H	A	K	M	WEIGHT lb. (kg)	
		WE	RF	RTJ								WE	RF/RTJ
2 (50)	2 (51)	14 1/2 (368)	14 1/2 (368)	14 5/8 (371)	5 1/2 (142)	-	-	21 5/8 (550)	-	13 3/4 (350)	-	-	159 (72)
3 (80)	3 (76)	15 (381)	15 (381)	15 1/8 (384)	7 1/4 (184)	-	-	26 (660)	-	11 3/4 (300)	-	-	240 (109)
4 (100)	4 (102)	18 (457)	18 (457)	18 1/8 (460)	11 5/8 (295)	-	-	30 3/4 (780)	-	13 3/4 (350)	-	-	381 (173)
6 (150)	6 (152)	24 (610)	24 (610)	24 1/8 (613)	14 3/8 (364)	25 3/8 (645)	13 (330)	44 5/8 (1132)	7 7/8 (200)	11 3/4 (300)	2 1/4 (56)	928 (421)	977 (443)
8 (200)	8 (203)	29 (737)	29 (737)	29 1/8 (740)	18 1/2 (470)	33 1/2 (850)	16 7/8 (430)	55 1/2 (1410)	8 5/8 (220)	19 5/8 (500)	2 7/8 (74)	1481 (672)	1559 (707)
10 (250)	10 (254)	33 (838)	33 (838)	33 1/8 (841)	21 5/8 (550)	39 3/8 (1000)	20 1/8 (510)	66 1/2 (1690)	9 1/2 (241)	19 5/8 (500)	3 5/8 (92)	2166 (983)	2280 (1034)
12 (300)	12 (305)	38 (965)	38 (965)	38 1/8 (968)	23 1/4 (590)	44 3/8 (1127)	22 7/8 (580)	77 1/4 (1963)	12 5/8 (320)	19 5/8 (500)	4 (102)	3601 (1634)	3791 (1720)
14 (350)	12 3/4 (324)	40 1/2 (1029)	40 1/2 (1029)	40 7/8 (1038)	27 1/2 (700)	51 5/8 (1310)	26 3/8 (670)	87 3/8 (2220)	12 5/8 (320)	19 5/8 (500)	4 (102)	5187 (2353)	5459 (2476)
16 (400)	14 3/4 (375)	44 1/2 (1130)	44 1/2 (1130)	44 7/8 (1140)	28 1/2 (724)	54 1/4 (1377)	28 1/8 (714)	93 7/8 (2386)	12 5/8 (320)	19 5/8 (500)	4 (102)	5760 (2613)	6063 (2750)
18 (450)	16 3/4 (425)	48 (1219)	48 (1219)	48 1/2 (1232)	35 3/8 (900)	63 3/4 (1620)	33 1/8 (840)	108 5/8 (2760)	16 1/8 (410)	31 1/2 (800)	4 1/2 (115)	7882 (3575)	8297 (3763)
20 (500)	18 5/8 (473)	52 (1321)	52 (1321)	52 1/2 (1334)	38 5/8 (980)	70 7/8 (1800)	36 5/8 (930)	119 5/8 (3040)	16 1/8 (410)	31 1/2 (800)	4 1/2 (115)	9549 (4331)	10051 (4559)
22 (550)	20 5/8 (524)	*	*	*	42 1/2 (1080)	76 3/4 (1950)	39 3/4 (1010)	129 7/8 (3300)	17 7/8 (453)	31 1/2 (800)	5 7/8 (150)	11823 (5363)	12445 (5645)
24 (600)	22 1/2 (572)	61 (1549)	61 (1549)	61 3/4 (1568)	46 1/8 (1170)	82 5/8 (2100)	43 1/4 (1100)	140 1/2 (3570)	19 5/8 (500)	31 1/2 (800)	6 1/8 (155)	15330 (6954)	16137 (7320)
26 (650)	24 3/8 (619)	*	*	*	49 1/4 (1250)	89 (2260)	46 1/2 (1180)	151 5/8 (3850)	19 5/8 (500)	31 1/2 (800)	6 1/8 (155)	18042 (8184)	18991 (8614)
28 (700)	26 1/4 (667)	*	*	*	53 1/8 (1350)	94 7/8 (2410)	49 5/8 (1260)	160 5/8 (4080)	26 (660)	31 1/2 (800)	8 1/2 (215)	21693 (9840)	22835 (10358)
30 (750)	28 1/8 (714)	*	*	*	56 3/4 (1440)	101 5/8 (2580)	53 1/8 (1350)	166 7/8 (4240)	26 (660)	31 1/2 (800)	8 1/2 (215)	25996 (11792)	27364 (12412)
32 (800)	30 7/8 (762)	*	*	*	60 1/4 (1530)	107 1/2 (2730)	56 1/4 (1430)	177 1/8 (4500)	-	-	-	30913 (14022)	32540 (14760)
34 (850)	31 3/4 (810)	*	*	*	63 3/4 (1620)	113 3/4 (2890)	59 7/8 (1520)	186 5/8 (4740)	-	-	-	37240 (16892)	39200 (17781)
36 (900)	33 5/8 (857)	*	*	*	66 1/8 (1680)	120 1/8 (3050)	63 1/4 (1605)	192 3/4 (4895)	-	-	-	42663 (19352)	44909 (20371)
38 (950)	35 1/2 (905)	*	*	*	70 1/2 (1790)	126 (3200)	66 1/8 (1680)	207 1/8 (5260)	-	-	-	50618 (22960)	53282 (24168)
40 (1000)	37 1/2 (953)	*	*	*	74 (1880)	132 5/8 (3370)	69 5/8 (1770)	213 (5410)	-	-	-	56764 (25748)	59752 (27103)
42 (1050)	39 3/8 (1000)	*	*	*	77 1/2 (1970)	139 (3530)	73 1/4 (1860)	227 1/2 (5780)	-	-	-	65080 (29520)	68505 (31074)
48 (1200)	45 (1143)	*	*	*	87 3/8 (2220)	157 1/2 (4000)	83 1/2 (2120)	258 1/4 (6560)	-	-	-	89665 (40672)	94385 (42813)

* Upon Request

Flanges up to 24 in. (600 mm) (except 22 in. (550 mm)) in accordance with ASME B16.5;
22 in. (550 mm) and above 24 in. (600 mm) in accordance with MSS-SP-44 if applicable.

Shaded Dimensions in accordance to ISO 14313
Butt Welding Ends according to ASME B16.25

G12

ASME CLASS 1500

Larger on request.
Reduced-bore valves
also available.

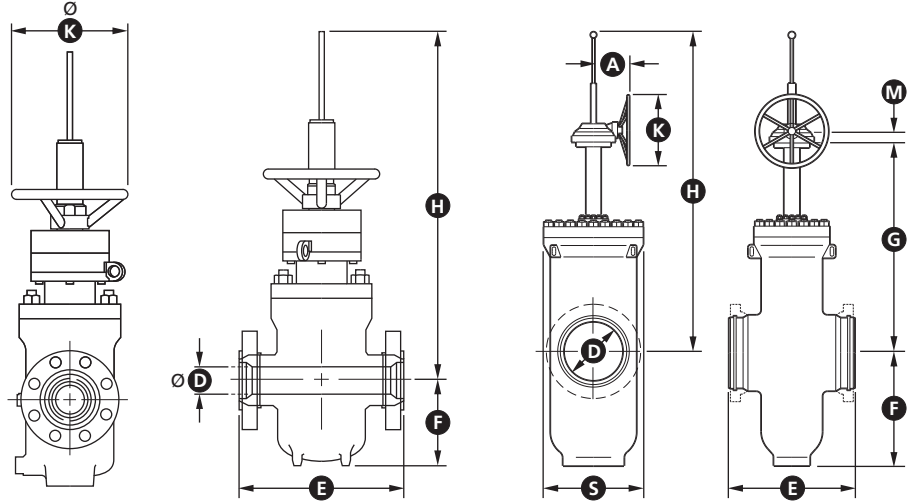

FROM 2 in. (50 mm) TO 4 in. (100 mm)

FROM 6 in. (150 mm) AND ABOVE

DIMENSIONS & WEIGHTS

SIZE in. (mm)	D	E			F	G	S	H	A	K	M	WEIGHT lb. (kg)	
		WE	RF	RTJ								WE	RF/RTJ
2 (50)	2 (51)	14 1/2 (368)	14 1/2 (368)	14 5/8 (371)	5 1/2 (142)	-	-	21 5/8 (550)	-	13 3/4 (350)	-	-	161 (73)
3 (80)	3 (76)	18 1/2 (470)	18 1/2 (470)	15 5/8 (473)	7 1/4 (184)	-	-	26 (660)	-	11 3/4 (300)	-	-	353 (160)
4 (100)	4 (102)	21 1/2 (546)	21 1/2 (546)	21 5/8 (547)	11 5/8 (295)	-	-	30 3/4 (780)	-	13 3/4 (350)	-	-	529 (240)
6 (150)	5 3/4 (146)	27 3/4 (705)	27 3/4 (705)	28 (711)	15 3/4 (400)	27 7/8 (710)	14 1/4 (363)	49 (1245)	8 5/8 (220)	19 5/8 (500)	2 7/8 (74)	1760 (798)	1852 (840)
8 (200)	7 5/8 (194)	32 3/4 (832)	32 3/4 (832)	33 1/8 (841)	20 3/8 (517)	36 3/4 (935)	18 5/8 (473)	61 1/8 (1551)	9 1/2 (241)	19 5/8 (500)	3 5/8 (92)	2808 (1274)	2956 (1341)
10 (250)	9 1/2 (241)	39 (991)	39 (991)	39 3/8 (1000)	23 7/8 (605)	43 1/4 (1100)	22 1/8 (561)	73 1/4 (1859)	12 5/8 (320)	19 5/8 (500)	4 (102)	4108 (1863)	4324 (1961)
12 (300)	11 3/8 (289)	44 1/2 (1130)	44 1/2 (1130)	45 1/8 (1146)	25 1/2 (649)	48 3/4 (1240)	25 1/8 (638)	85 (2159)	16 1/8 (410)	31 1/2 (800)	4 1/2 (115)	6829 (3098)	7189 (3261)
14 (350)	12 1/2 (318)	49 1/2 (1257)	49 1/2 (1257)	50 1/4 (1276)	30 3/8 (770)	56 3/4 (1441)	29 (737)	96 1/8 (2442)	16 1/8 (410)	31 1/2 (800)	4 1/2 (115)	9835 (4461)	10353 (4696)
16 (400)	14 1/4 (362)	54 1/2 (1384)	54 1/2 (1384)	55 3/8 (1407)	31 3/8 (796)	59 5/8 (1515)	30 7/8 (785)	103 3/8 (2625)	17 7/8 (453)	31 1/2 (800)	5 7/8 (150)	10922 (4954)	11497 (5215)
18 (450)	16 (406)	*	*	*	39 (990)	70 1/8 (1782)	36 3/8 (924)	119 1/2 (3036)	19 5/8 (500)	31 1/2 (800)	6 1/8 (155)	14947 (6780)	15733 (7137)
20 (500)	18 (454)	*	*	*	42 1/2 (1078)	78 (1980)	40 1/4 (1023)	131 5/8 (3344)	19 5/8 (500)	31 1/2 (800)	6 1/8 (155)	18107 (8213)	19060 (8646)
22 (550)	20 (500)	*	*	*	46 3/4 (1188)	84 1/2 (2145)	43 3/4 (1111)	142 7/8 (3630)	26 (660)	31 1/2 (800)	8 1/2 (215)	22420 (10170)	23600 (10705)
24 (600)	21 (546)	*	*	*	50 5/8 (1287)	91 (2310)	47 5/8 (1210)	154 5/8 (3927)	26 (660)	31 1/2 (800)	8 1/2 (215)	29071 (13186)	30601 (13880)
26 (650)	22 5/8 (575)	*	*	*	54 1/8 (1375)	97 7/8 (2486)	51 1/8 (1298)	166 3/4 (4235)	-	-	-	34213 (15519)	36014 (16336)
28 (700)	24 1/4 (616)	*	*	*	58 1/2 (1485)	104 3/8 (2651)	54 5/8 (1386)	176 3/4 (4488)	-	-	-	41138 (18660)	43303 (19642)
30 (750)	25 7/8 (657)	*	*	*	62 3/8 (1584)	111 3/4 (2838)	58 1/2 (1485)	183 5/8 (4664)	-	-	-	49297 (22361)	51891 (23538)
32 (800)	27 1/2 (699)	*	*	*	66 1/4 (1683)	118 1/4 (3003)	61 7/8 (1573)	194 7/8 (4950)	-	-	-	58621 (26591)	61707 (27990)
34 (850)	29 1/8 (740)	*	*	*	70 1/8 (1782)	125 1/8 (3179)	65 7/8 (1672)	205 1/4 (5214)	-	-	-	70620 (32033)	74337 (33719)
36 (900)	30 3/4 (781)	*	*	*	72 3/4 (1848)	132 1/8 (3355)	69 1/2 (1766)	212 (5385)	-	-	-	80904 (36698)	85163 (38629)
38 (950)	32 3/8 (822)	*	*	*	77 1/2 (1969)	138 5/8 (3520)	72 3/4 (1848)	227 3/4 (5786)	-	-	-	95988 (43540)	101040 (45832)
40 (1000)	38 (966)	107 7/8 (2740)	*	*	81 (2058)	150 5/8 (3826)	89 3/4 (2280)	259 7/8 (6600)	-	-	-	128970 (58500)	-
42 (1050)	40 (1016)	118 1/8 (3000)	*	*	81 3/8 (2065)	159 1/2 (4050)	93 1/4 (2370)	273 5/8 (6950)	-	-	-	132277 (60000)	-
48 (1200)	46 (1168)	141 3/4 (3600)	*	*	96 (2440)	169 1/4 (4300)	95 1/4 (2420)	-	-	-	-	-	-

* Upon Request

Flanges up to 24 in. (600 mm) (except 22 in. (550 mm)) in accordance with ASME B16.5;
22 in. (550 mm) and above 24 in. (600 mm) in accordance with MSS-SP-44 if applicable.

Shaded Dimensions in accordance with ISO 14313
Butt Welding Ends according to ASME B16.25

G12

ASME CLASS 2500

Larger on request.
Reduced-bore valves
also available.

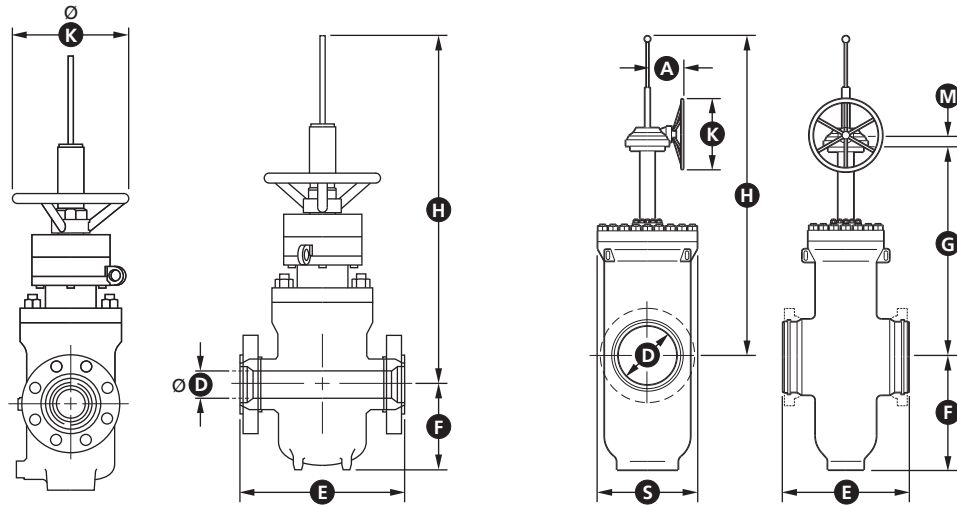

FROM 2 in. (50 mm) TO 3 in. (80 mm)

FROM 4 in. (100 mm) AND ABOVE

DIMENSIONS & WEIGHTS

SIZE in. (mm)	D	E			F	G	S	H	A	K	M	WEIGHT lb. (kg)	
		WE	RF	RTJ								WE	RF/RTJ
2 (50)	1 3/4 (44.5)	17 3/4 (451)	17 3/4 (451)	17 7/8 (454)	6 1/4 (160)	-	-	27 1/2 (700)	-	-	-	-	198 (90)
3 (80)	2 1/2 (64)	22 3/4 (578)	22 3/4 (578)	23 (584)	7 1/4 (184)	-	-	32 1/4 (820)	-	-	-	-	441 (200)
4 (100)	3 1/2 (89)	26 1/2 (673)	26 1/2 (673)	26 7/8 (683)	11 5/8 (295)	-	-	37 3/8 (950)	-	-	-	-	694 (315)
6 (150)	5 1/8 (131)	36 (914)	36 (914)	36 1/2 (927)	*	*	*	*	*	*	*	*	*
8 (200)	7 (179)	40 1/4 (1022)	40 1/4 (1022)	40 7/8 (1038)	*	*	*	*	*	*	*	*	*
10 (250)	8 3/4 (223)	50 (1270)	50 (1270)	50 7/8 (1292)	*	*	*	*	*	*	*	*	*
12 (300)	10 3/8 (265)	56 (1422)	56 (1422)	56 7/8 (1445)	*	*	*	*	*	*	*	*	*
14 (350)	11 1/2 (292)	*	*	*	*	*	*	*	*	*	*	*	*
16 (400)	13 1/8 (333)	*	*	*	*	*	*	*	*	*	*	*	*
18 (450)	14 3/4 (374)	*	*	*	*	*	*	*	*	*	*	*	*
20 (500)	16 1/2 (419)	*	*	*	*	*	*	*	*	*	*	*	*
22 (550)	*	*	*	*	*	*	*	*	*	*	*	*	*
24 (600)	*	*	*	*	*	*	*	*	*	*	*	*	*

* Upon Request

Flanges up to 24 in. (600 mm) (except 22 in. (550 mm)) in accordance with ASME B16.5;
22 in. (550 mm) and above 24 in. (600 mm) in accordance with MSS-SP-44 if applicable.

Shaded Dimensions in accordance to ISO 14313
Butt Welding Ends according to ASME B16.25

G12 QUALITY SYSTEM AND QUALIFICATION TESTING

QUALITY ASSURANCE PROGRAM

GROVE operates a high level quality assurance program to ensure all valves are designed and manufactured to the highest standards available using the latest technology.

GROVE Quality Assurance Program covers the entire operation from order entry to final inspection and field service in accordance with:

ISO 9001, API Q1

GROVE has held the ISO 9001 Certificate of conformity since 1990 and maintains the API Licence #1.

All products are supplied with Certified Test Reports which include chemical-physical analysis of the materials, pressure testing along with any other specified special test certification.



INSPECTION, TESTING ...



The GROVE Quality Control department verifies all processes from material receipt, to final customer inspection including a liaison with approved inspection, and certifying authorities.

All products can be supplied with Certified Test Reports which include Pressure Testing, NDT, chemical-physical analysis, along with any other customer specified test certifications.

All of the valves are hydrostatically tested per API 6D Standard.

A complete range of equipment and instrumentation are available to perform standard and special tests.

... AND PROCESSES

All welding as well as internal and external coating are supported by detailed procedures. GROVE operates its own in-house Electroless Nickel Plating (ENP) facility.

In-house HVOF process for TCC application and in-house welding overlay with 5 axis robots.

Strict quality control procedures for critical process conditions and for the plated components maintain plating consistency. Vendors of special processes are carefully selected within ISO 9000 Approved Facility or pre-qualified and surveyed by GROVE.

RESEARCH AND DEVELOPMENT LAB

GROVE G12 Gate Valves are designed in accordance with the applicable or requested codes and are subjected to full in-house qualification testing.

Our in-house testing facilities with the participation of the major oil and gas companies R&D programs allows GROVE to supply the highest quality products

Hydraulic and gas sealing tests, functional tests, cycling and torque tests are all carried out on prototype valves.

These test procedures ensure that the design safety factors, the maximum allowable leakage rates and the expected valve service life are achieved.

STRUCTURAL VERIFICATION

The GROVE engineering department operates the most advanced 3D CAD system and conducts Finite Element Analysis (FEA) to simulate various load conditions to determine a components suitability for the intended service.

HIGH PRESSURE GAS TESTING

Customer specifications may require more detailed testing in addition to conventional hydrostatic testing.

GROVE is fully equipped to carry enhanced gas tests, at ambient, low and high temperatures using specially equipped bunkers.

External leakage rates (if any) are verified by means of a mass spectrometer.

Leakages through the seats (if any) are verified by means of calibrated flow meters.

For low and high temperature service, gas testing can be performed to customer specified critical conditions. GROVE maintains test facilities for various valve dimensions.

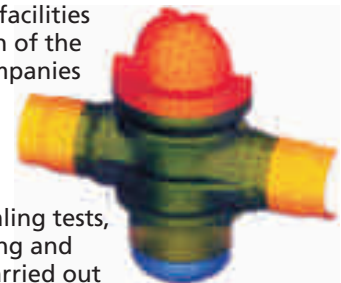

TRADEMARK INFORMATION

GROVE® is a registered trademark which is owned by Cameron.

This document contains references to registered trademarks or product designations, which are not owned by Cameron.

Trademark	Owner
Celcon	Hoechst Celanese Corporation
Delrin	E.I. DuPont De Nemours & Company
Fluorel	Minnesota Mining and Manufacturing Company
Hastelloy	Haynes International, Inc
Hycar	Hydrocarbon Chemical and Rubber Company
Hypalon	E.I. DuPont De Nemours & Company
Inconel	INCO Nickel Sales, Inc.
Monel	INCO Alloys International, Inc.
Nordel	E.I. DuPont De Nemours & Company
Stellite	Stoody Deloro Stellite, Inc.
Teflon	E.I. DuPont De Nemours & Company
Viton	E.I. DuPont De Nemours & Company

**VALVES & MEASUREMENT**

3250 Briarpark Drive, Suite 300
Houston, Texas 77042
USA Toll Free 800 323 9160

For the most current contact and location information go to: www.c-a-m.com/valvesandmeasurement