

# NAVCO® S20 Ball Valves

Two-piece threaded-end ball valves, fire-tested and certified to API 607 5th edition

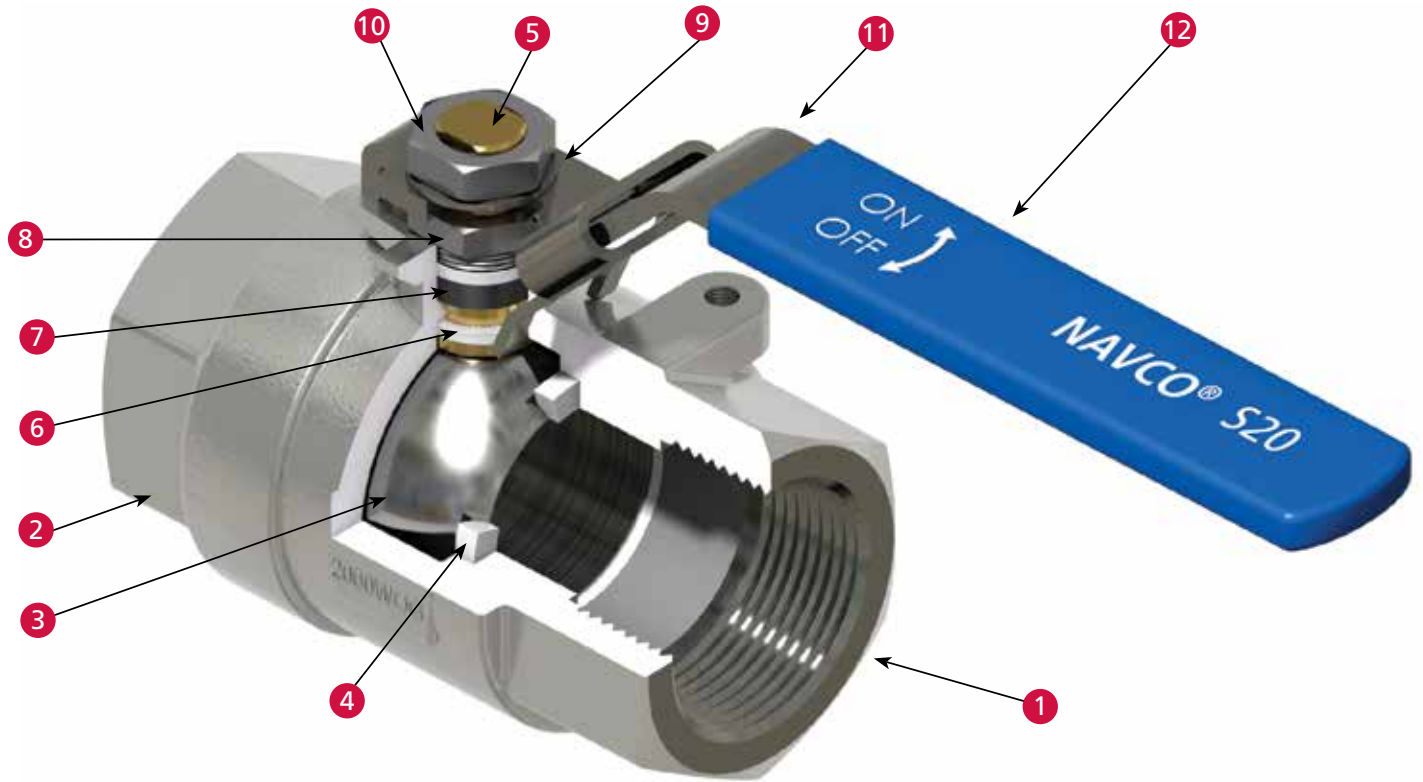

## Features and Benefits

- Two-piece threaded-end ball valve, full port, 2000 WOG
- Seal welded in full stainless version
- Investment cast body
- Fire-tested and certified to API 607 5th edition
- Working pressure: 2000 psi
- Conforms to NACE MR0175 (2002) specifications
- Positively retained stem design
- Handle locking device

## Materials List

Item	Quantity	Part	Material
1	1	Body	WCB or CF8M
2	1	Cap	WCB or CF8M
3	1	Ball	AISI 316
4	2	Seat	RPTFE
5	1	Stem	AISI 316
6	2	Stem Seal	RPTFE
7	1	Stem Packing	Graphite
8	1	Packing Nut Gland	AISI 304
9	1	Lock Washer	AISI 304
10	1	Nut	A2-70
11	1	Handle	SS 201
12	1	Handle Sleeve	Vinyl

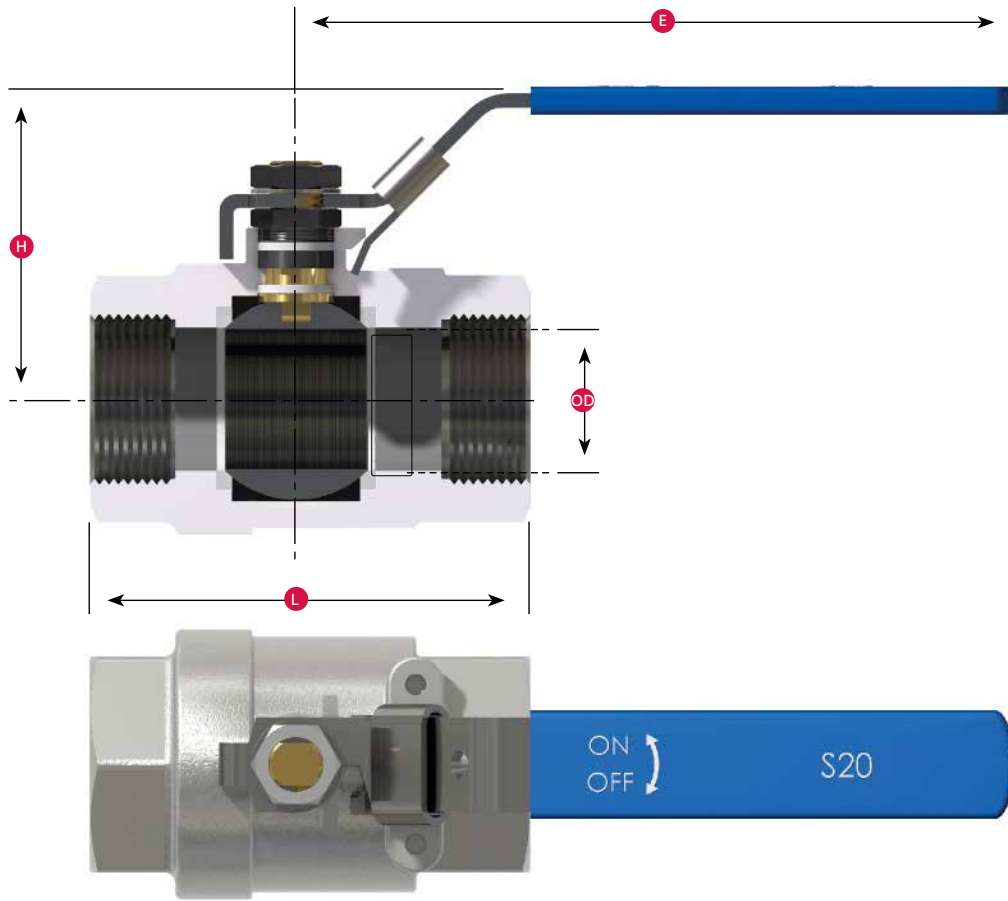

### Dimensions

Size		OD	L	E	H
in.	(mm)				
1/4	(6.4)	0.42 (10.7)	2.36 (59.9)	3.93 (99.8)	1.89 (48.1)
3/8	(9.7)	0.49 (12.4)	2.36 (59.9)	3.93 (99.8)	1.89 (48.1)
1/2	(12.7)	0.59 (15.0)	2.95 (74.9)	4.33 (110.0)	2.28 (57.9)
3/4	(19.1)	0.78 (19.8)	3.15 (80.0)	4.72 (119.9)	2.36 (59.9)
1	(25.4)	0.98 (24.9)	3.54 (89.9)	5.90 (149.9)	3.03 (77.0)
1-1/2	(38.1)	1.50 (38.1)	4.72 (119.9)	7.08 (179.8)	3.62 (92.0)
2	(50.8)	1.97 (50.0)	5.51 (140.0)	7.08 (179.8)	4.13 (104.9)

### Seat Rating

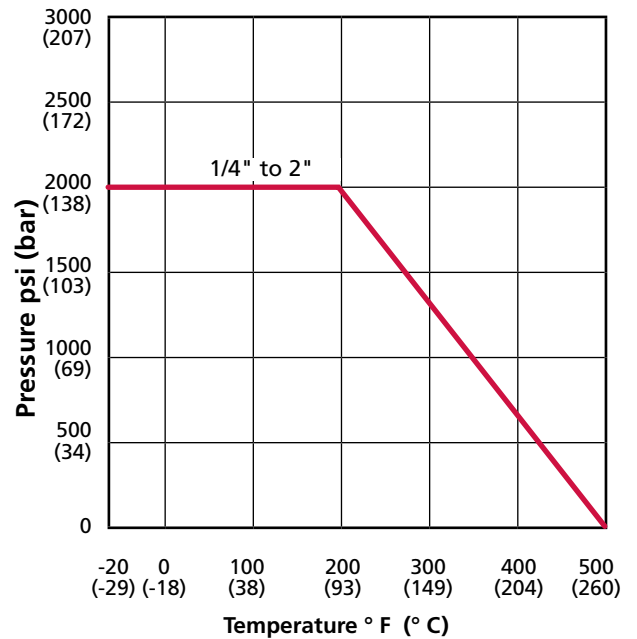

3250 Briarpark Drive, Suite 300  
Houston, TX 77042  
USA  
Tel 1 281 499 8511